

VOLVO WHEEL LOADERS  
**L110G, L120G**

20-22 t 258-268 hp



# A PASSION FOR PERFORMANCE.

At Volvo Construction Equipment, we're not just coming along for the ride. Developing products and services that raise productivity – we are confident we can lower costs and increase profits for industry experts. Part of the Volvo Group, we are passionate about innovative solutions to help you work smarter – not harder.

## Helping you to do more

Doing more with less is a trademark of Volvo Construction Equipment. High productivity has long been married to low energy consumption, ease of use and durability. When it comes to lowering life-cycle costs, Volvo is in a class of its own.

## Designed to fit your needs

There is a lot riding on creating solutions that are suited to the particular needs of different industry applications. Innovation often involves high technology – but it doesn't always have to. Some of our best ideas have been simple, based on a clear and deep understanding of our customers' working lives.



## You learn a lot in 175 years

Over the years, Volvo has advanced solutions that have revolutionized the use of construction equipment. No other name speaks Safety louder than Volvo. Protecting operators, those around them and minimizing our environmental impact are traditional values that continue to shape our product design philosophy.

## We're on your side

We back the Volvo brand with the best people. Volvo is truly a global enterprise, one that is on standby to support customers quickly and efficiently – wherever they are.

## We have a passion for performance.

### A strong, dedicated, capable dealer network.

Our dealers are strategically located throughout North America to provide the equipment you need and the parts and service support you demand for a productive and profitable operation.

The strength of our dealer network is enhanced with extensive individualized product and product support training at our state-of-the-art Technical Training Center in Asheville and through hands-on training. At our nearby 80-acre Product Demonstration Center, visitors operate equipment from our entire product line under a variety of simulated working conditions. Both facilities are in year-round use by our dealers and customers – more than 2,000 visit each year. **Building the best starts right here.**

The products designed and manufactured by Volvo Construction Equipment have their beginnings at the most advanced Research & Design centers in the industry. Volvo CE machines are designed in 11 R&D centers and produced in 15 manufacturing facilities across the world.

The major R&D center and manufacturing plant in the Americas is located in Shippensburg, Pennsylvania. This facility has been in operation for over 30 years and – with its recently added 200,000 sq ft expansion – now covers 570,000 sq ft on an 80 acre campus. Dedicated work teams and highly advanced technologies and techniques using the Volvo Production System ensure continuous quality improvements, labor savings and cost control to reach the high quality that our customers have come to expect from Volvo.

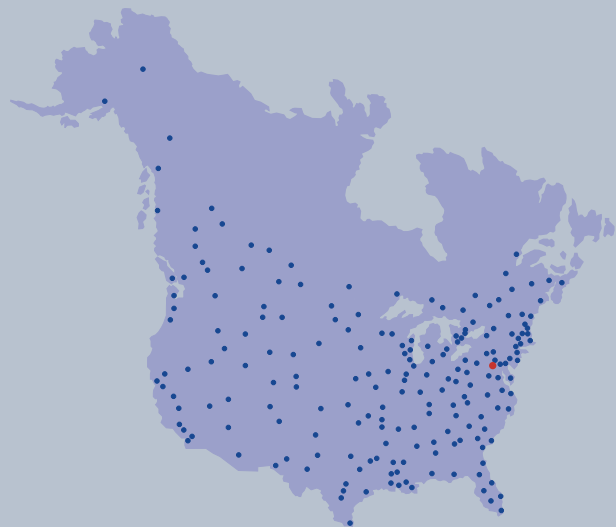



Mack Trucks



Volvo Construction Equipment



Volvo Penta



Volvo Trucks



Renault Trucks



UD Trucks



Volvo Buses



Volvo Aero



Volvo Financial Services

# FLEXIBLE, TO MEET YOUR NEEDS.

The new Volvo L110G and L120G wheel loaders are strong and versatile; purpose-built to move more material, with greater flexibility. Designed to work on any site, these efficient machines can use a range of Volvo attachments to handle all types of production – from quarries to road construction – making the Volvo L110G and L120G great ‘allrounder’ machines.



## Productive TP linkage

Volvo's patented Torque Parallel linkage delivers high breakout torque throughout the entire range, including the highest lift position, making it ideal in applications such as log handling.



## Parallel lift

Parallel lift enables you to get closer to the materials and raise them quickly, with smooth, horizontal stability. Load faster and more accurately to save time for increased productivity.



## Load sensing hydraulics

Load-sensing hydraulics match power when it's needed for lower fuel consumption and high performance. Faster lift and tilt functions are achieved by variable-flow axial piston pumps, with high pump capacity for superior control of the load and attachments. Increased working hydraulic pressure enables greater lifting and break-out force.

# PURPOSE-BUILT TO PERFORM.

The Volvo L110G and L120G are built to perform precision-demanding applications with unbeatable productivity. All components are developed and manufactured by Volvo as one unit to provide optimized performance, lower fuel consumption and maximum reliability.



## Fuel saving Automatic Power Shift

The Automatic Power Shift system means the machine always operates in the most suitable gear according to speed, kick down and engine braking. Fully Automatic Power Shift (FAPS) switches to 1st gear when additional power is required for easier penetration that helps lower fuel consumption..

## Differential lock for traction

The front axle is mounted to the front frame and equipped with an electro-hydraulic operated differential lock. Transfers 100% power to the wheels and reduces tire slippage to provide outstanding traction on soft and slippery ground.



## Optimized drivetrain

Volvo designed, Volvo manufactured – that applies to the whole machine. The engine, transmission, axles, hydraulics and steering are developed as one unit to provide optimized performance, and superior fuel consumption.



## Heavy duty axle

Volvo's heavy-duty wet brake axles promote a longer service life. Axle housings absorb all loads from the machine weight distribution. Well-designed axle shafts only transmit torque to the hub reductions, reducing working stresses on the axle.

# CONSUMING LESS WHILE GIVING MORE.

Volvo machines are fuel efficient and environmentally responsible. Fuel consumption is significantly lowered in the L110G and L120G through Volvo's turbocharged Tier 4 Interim engine, diesel particle filter to incinerate exhaust emissions and accelerator eco pedal to promote operator efficiency. More is achieved, less is wasted.



## Lowering emissions

High torque at low RPM is achieved for industry-leading performance. Fuel consumption is lowered by a common rail system, cooled exhaust, gas recirculation and diesel oxidation catalyst and diesel particulate filter with active and passive regeneration. Volvo's 8 liter, 6-cylinder turbocharged diesel engine has low emission levels that meet Tier 4 Interim engine requirements.

## Fuel efficient Volvo V-ACT

Volvo Combustion Technology, V-ACT, is tailored for use in demanding applications. Fuel injection is electronically controlled based on temperature, pressure, load and engine speed in order to achieve optimal combustion. The result: high performance and low emissions.

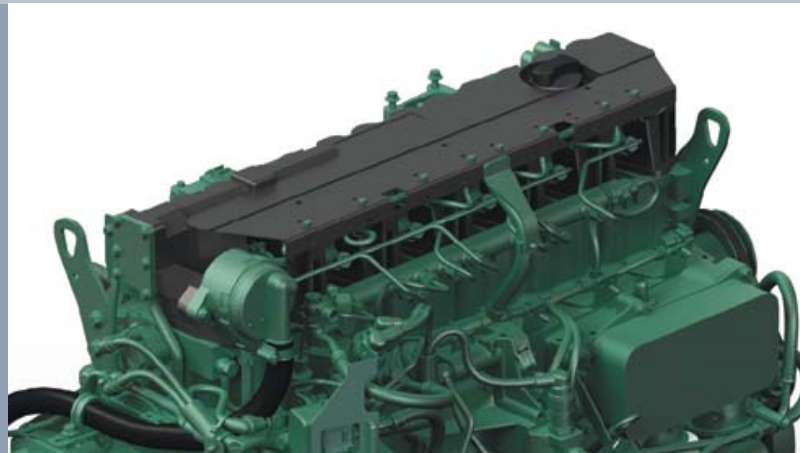

## Diesel particle filter

The Diesel Particulate Filter (DPF) includes a Diesel Oxidation catalyst function and an external regeneration burner, which works as you operate. The system temporarily holds the soot and then incinerates it, reducing carbon emissions. The process reduces emissions without stopping production.

## Eco pedal

The eco pedal encourages the operator to engage the throttle pedal with ease to lower fuel consumption, by applying the appropriate amount of mechanical counter pressure (push-back). This economical pedal feature promotes operator efficiency by avoiding excessive fuel use.

# QUICK ACCESS, EASY MAINTENANCE.

Time is money. That's why Volvo wheel loaders are built with quick access to service areas for easy maintenance. Contronics system inside the cab monitors the machine's performance for up-to-the-minute service diagnostics to keep your machine running longer.

## Contronics

Volvo Contronics is a computerized machine electronics and monitoring system. Continuously monitors the machine, operation and performance in real time. Provides diagnostic functions and information needed for optimal operation. Fast, easy electronic level checks. More uptime each day.

## Maintenance-free cradles

The rear axle cradles are maintenance free. Rear-axle bridge connects the axle to the frame and includes two grease-lubricated-for-life roller bearings. Front bridge includes two oil bath, pre-filled-for-life bushings. Minimizes force on the axle and helps to maintain a low centre of gravity. Cradle oscillation pins are sealed to keep grease/oil in and dirt out for easy maintenance.

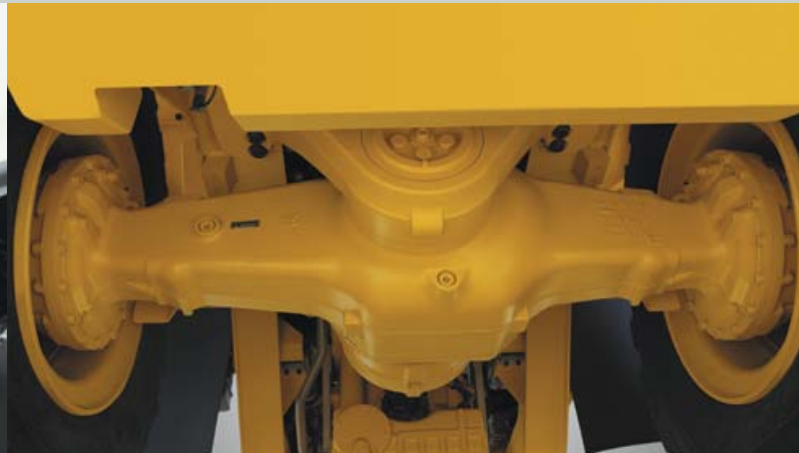

## Hydraulic cooling fan

Hydraulically driven, electronically controlled cooling fan works only when needed to save fuel. The fan is located behind engine and radiator and speeds-up when necessary. Higher engine power, lower fuel consumption and lower sound levels are achieved.

## Easy access to the engine

The engine hood is newly designed and can be electrically opened backwards for quick easy access to the engine. Large ventilation sections to the radiator keep the engine cool for sustained performance and a wide opening angle allows for a better overview of the full engine compartment.

# KEEPING YOU FOCUSED AND IN CONTROL.

## Electro Hydraulic Servo Control

The servo controls are mounted on the operator seats armrest, to keep them in place despite seat movement. The high quality controls allow the selection of easy settings from inside the cab such as: return to dig, boom and tilt detent.



## Climate control

No matter what the weather does, Volvo keeps the operator at a pre-selected temperature with its in-cab climate control system.

## Noise reduction

Thanks to noise and vibration dampening, enables the operator to concentrate on the task in hand, with minimal distraction.



## Safe and roomy cab

Safety and visibility are at the forefront of design for Volvo's cab. The industry-tested and ROPS/FOPS- approved cab provides excellent all-round visibility. The roomy cab gives the operator good comfort and to store personal items.





Operators need to remain focused and sharp. Volvo's industry-leading cab provides a spacious, quiet and safe operator environment, whatever the conditions outside, helping operators to stay efficient, all day.

# CONNECT AND GO.

All genuine Volvo attachments are purpose-built with the same quality as the rest of the machine. They're designed as an integrated part of the wheel loader for which they were intended, their functions and properties perfectly matched to parameters such as link-arm geometry, breakout force, rim pull and lifting force. That's why the machine and attachment work in perfect harmony, forming a dependable cohesive unit to get the job done – safely and efficiently.

## Rehandling buckets increase fuel efficiency:

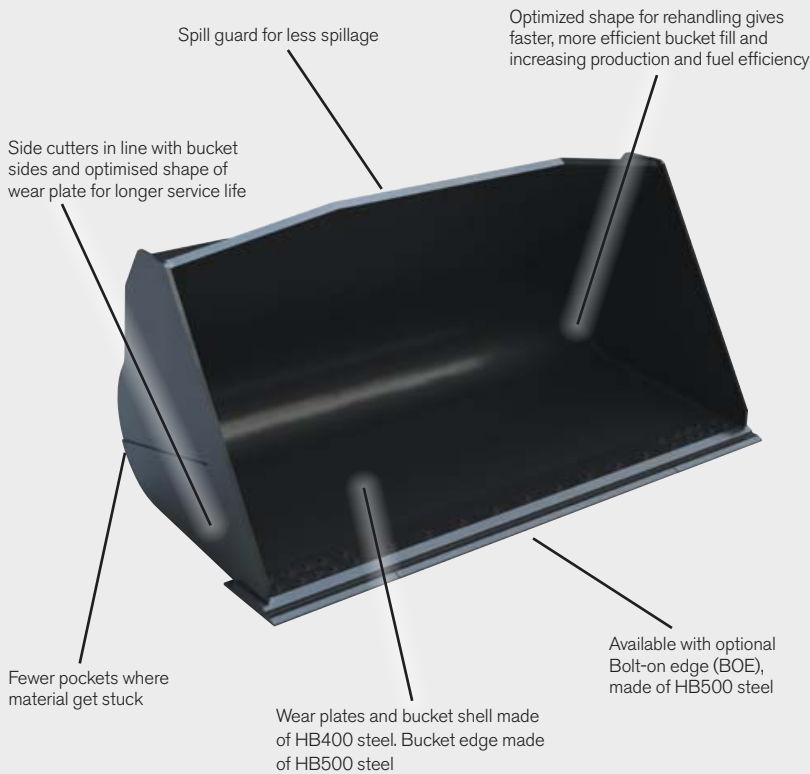

### Volvo Tooth system

The Volvo patented vertical locking device makes mounting and removing fast and easy. For Volvo buckets there are a also wide selection of cutting edges and segments in high strength steel 500 HB to protect the bucket from wear.

### Optional Attachments

	L110G	L120G
<b>Buckets:</b>		
Rock straight or spade nose	•	•
General purpose	•	•
Re-handling	•	•
Light material	•	•
<b>Wear parts:</b>		
Bolt-on and weld-on bucket teeth	•	•
Segments	•	•
Cutting edge in three sections, bolt-on	•	•
<b>Fork equipment</b>		
<b>Material handling arm</b>	•	•
<b>Log grapples</b>	•	•

# STRENGTH TO SUPPORT YOU AND YOUR BUSINESS.

The day you receive your new Volvo Wheel Loader is just the start of your working relationship with Volvo. From service and maintenance to our CareTrack telematics system – Volvo has a comprehensive and sophisticated aftermarket portfolio to continuously add value to your business.



**CareTrack** - Volvo's telematics system works with our exclusive machine tracking info system, MATRIS, using guided diagnostics to track and analyze machines remotely - minimizing costs and maximizing uptime.



**Customer Support Agreements** - Gives you peace of mind by reducing total ownership costs, maximizing uptime, and distributing maintenance and major repair costs.



**Attachments** - Providing customers with a wide variety of attachments keep your machine working and open up new job opportunities.

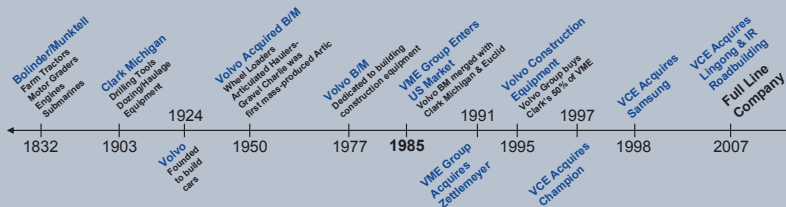

When it comes to your machine, our Volvo trained technicians are the experts.

Our technicians work with industry leading diagnostic tools and techniques, using only Genuine Volvo Parts to deliver the highest levels of quality and service. Talk to your Volvo dealer about how genuine Volvo services can best provide the service and maintenance plan that is the right fit for you and your business.

State-of-the-art machines require state-of-the-art support and your Volvo dealer can provide a catalogue of services designed to get the most out of your machine, helping you maximise uptime, productivity and residual value. Your Volvo dealer can provide a number of sophisticated support offers, including:

Service plans ranging from routine wear inspections, through to comprehensive maintenance and repair agreements.

Analysis and diagnostics to help you understand how your machine is running, highlight potential maintenance issues and identify where performance can be improved.

Eco Operator training courses can help your operators work towards a safer, more productive and fuel efficient performance.

# TWO MACHINES THAT HAVE IT ALL.

## Automatic Power Shift

The machine always operates in the most suitable gear according to application.



## Safe and roomy cab

ROPS/FOPS tested cab with conveniently-placed controls, noise reduction and premium air filter.



## Productive TP linkage

High breakout torque, even at the highest lift position. Excellent link geometry gives excellent parallel movement and visibility.



## CareTrack

CareTrack is the Volvo telematics system. It is equipped as standard on this machine and is designed to provide information to help improve productivity and efficiency.

## Load-sensing hydraulics

Variable- flow axial piston pumps for superior control and fast hydraulics.

## Electro hydraulic servo control

Mounted on the cab seat for comfortable operation and control.



### Contronics

Relays necessary diagnostics to the operator via a screen so problems can be found early to reduce down-time and improve safety.



### Easy access to the engine

New electronic opening design for easy service access. Bigger ventilation panels keep the radiator efficient.



### Optimized drivetrain

Engine, transmission, axles, hydraulics and steering are developed as one unit by Volvo to provide optimized performance and maximum reliability.

### Diesel particulate filter

Includes a Diesel Oxidation catalyst function and an external regeneration burner to incinerate particulates and reduce emissions.



### Lowering emissions

Tier 4 Interim certified engine for low fuel consumption and low emissions.

### Heavy duty axle

Absorb the weight for optimal torque, reduced stresses and longer life.



# VOLVO L110G, L120G IN DETAIL.



## Engine

6-cylinder, 8 liters in-line turbocharged diesel engine with an advanced fuel injection system with the common rail. Fuel is distributed under high pressure from a high-pressure accumulator, the rail. One camshaft-driven high pressure pump deliver the fuel to the rail and then further on via high-pressure pipes to the electro-hydraulically operated fuel injectors. Cooled exhaust gas recirculation and particulate filter with active and passive regeneration. **Air cleaning:** Two-stage Cyclone pre-cleaner - primary filter - secondary filter **Cooling system:** Hydrostatic, electronically controlled fan. Intercooler of the air-to-air type.

## L110G

Engine		D8H (Tier 4i)
Max power at	r/s (r/min)	28,3 (1,700)
SAE J1995 gross	kW / hp	191 / 260
ISO 9249, SAE J1349 net	kW / hp	190 / 258
Max torque at	r/s (r/min)	23,3 (1,400)
SAE J1995 gross	Nm / lbf-ft	1255 / 926
ISO 9249, SAE J1349	Nm / lbf-ft	1248 / 920
Economic working range	r/s (r/min)	14,2-35 (850-2,100)
Displacement	l / gal	7,75 / 2

## L120G

Engine		D8H (Tier 4i)
Max power at	r/s (r/min)	28,3 (1,700)
SAE J1995 gross	kW / hp	201 / 270
ISO 9249, SAE J1349 net	kW / hp	200 / 268
Max torque at	r/s (r/min)	25,0 (1,500)
SAE J1995 gross	Nm / lbf-ft	1320 / 974
ISO 9249, SAE J1349 net	Nm / lbf-ft	1312 / 968
Economic working range	r/s (r/min)	14,2-35 (850-2,100)
Displacement	l / gal	7,75 / 2

## L110G

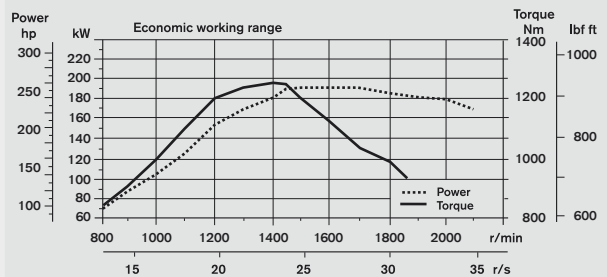

## L120G

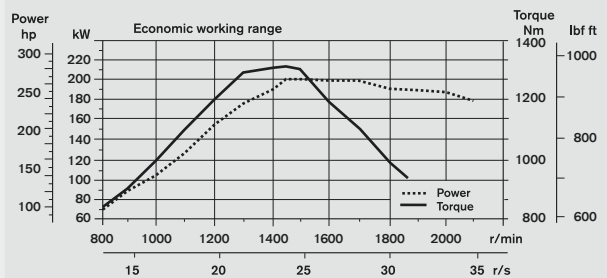



### Drivetrain

**Torque converter:** Single-stage.

**Transmission:** Volvo countershaft transmission with single lever control. Fast and smooth shifting of gears with Pulse Width Modulation (PWM) valve.

**Transmission:** Volvo Automatic Power Shift (APS) with fully automatic shifting 1-4 and mode selector with 4 different gear shifting programs, including AUTO.

**Axles:** Volvo fully floating axle shafts with planetary hub reductions and cast steel axle housing. Fixed front axle and oscillating rear axle. 100% differential lock on the front axle.

#### L110G

<b>Transmission</b>	Volvo	HTE 206
<b>Torque multiplication</b>		2,47:1
	1st gear km/h (mph)	7 (4.35)
<b>Maximum speed, forward/reverse</b>	2nd gear km/h (mph)	13.5 (8.1)
	3rd gear km/h (mph)	28 (17.4)
	4th gear* km/h (mph)	40 (24.9)
<b>Measured with tires</b>		750/65R25
<b>Front axle/rear axle</b>		AWB 31/AWB 30
<b>Rear axle oscillation ±</b>	°	± 13
<b>Ground clearance at 13° osc.</b>	mm (in)	460 (18.1)

#### L120G

<b>Transmission</b>	Volvo	HTE 206
<b>Torque multiplication</b>		2,47:1
	1st gear km/h (mph)	7 (4.35)
<b>Maximum speed, forward/reverse</b>	2nd gear km/h (mph)	13.5 (8.1)
	3rd gear km/h (mph)	28 (17.4)
	4th gear* km/h (mph)	40 (24.9)
<b>Measured with tires</b>		750/65R25
<b>Front axle/rear axle</b>		AWB 31/AWB 30
<b>Rear axle oscillation ±</b>	°	± 13
<b>Ground clearance at 15° osc.</b>	mm (in)	460 (18.1)

\* limited by ECU

### Electrical system

**Central warning system:** Contronic electrical system with central warning light and buzzer for following functions: - Serious engine fault - Low steering system pressure - Over speed warning engine - Interruption in communication (computer fault) Central warning light and buzzer with the gear engaged for the following functions. - Low engine oil pressure - High engine oil temperature - High charge air temperature - Low coolant level - High coolant temperature - High crank case pressure - Low transmission oil pressure - High transmission oil temperature - Low brake pressure - Engaged parking brake - Fault on brake charging - Low hydraulic oil level - High hydraulic oil temperature - Overspeeding in engaged gear - High brake cooling oil temperature front and rear axles.

#### L110G, L120G

<b>Voltage</b>	V	24
<b>Batteries</b>	V	2 x 12
<b>Battery capacity</b>	Ah	2 x 170
<b>Cold cranking capacity, approximate</b>	A	1000
<b>Batteries</b>		
<b>Alternator rating</b>	W/A	3420/120
<b>Starter motor output</b>	kW	5.5

### Brake system

**Service brake:** Volvo dual-circuit system with nitrogen charged accumulators. Outboard mounted hydraulically operated, fully sealed oil circulation cooled wet disc brakes. The operator can select automatic de-clutch of the transmission when braking through a switch in the A-pillar.

**Parking brake:** Fully sealed, wet multi-disc brake built into the transmission. Applied by spring force, electro-hydraulically released with a switch on the instrument panel.

**Secondary brake:** Dual brake circuits with rechargeable accumulators. One circuit or the parking brake fulfills all safety requirements.

**Standard:** The brake system complies with the requirements of ISO 3450.

# VOLVO L110G, L120G IN DETAIL.



## Cab

**Instrumentation:** All important information is centrally located in the operator's field of vision. Display for Contronic monitoring system.

**Heater and defroster:** Heater coil with filtered fresh air and fan with auto and 11 speeds. Defroster vents for all window areas.

**Operator's seat:** Operator's seat with adjustable suspension and retractable seat belt. The seat is mounted on a bracket on the rear cab wall and floor. The forces from the retractable seat belt are absorbed by the seat rails.

**Standard:** The cab is tested and approved according to ROPS (ISO 3471, SAE J1040), FOPS (ISO 3449). The cab meets with requirements according to ISO 6055 (Operator overhead protection - Industrial trucks) and SAE J386 ("Operator Restraint System").

		<b>L110G</b>
<b>Emergency exit:</b>	Use emergency hammer to break window	
<b>Sound level in cab according to ISO 6396/SAE J2105</b>		
	dB(A)	68
<b>External sound level according to ISO 6396/SAE J2105</b>		
	dB(A)	106
<b>Ventilation</b>	m <sup>3</sup> (yd <sup>3</sup> )/min	9 (11.8)
<b>Heating capacity</b>	kW	16
<b>Air conditioning (optional)</b>	kW	7.5

		<b>L120G</b>
<b>Emergency exit:</b>	Use emergency hammer to break window	
<b>Sound level in cab according to ISO 6396/SAE J2105</b>		
	LpA	dB(A) 68
<b>External sound level according to ISO 6395/SAE J2104</b>		
	LwA	dB(A) 106
<b>Ventilation</b>	m <sup>3</sup> (yd <sup>3</sup> )/min	9 (11.8)
<b>Heating capacity</b>	kW	16
<b>Air conditioning (optional)</b>	kW	7.5

## Lift arm system

Torque Parallel linkage (TP-linkage) with high breakout torque and parallel action throughout the entire lifting range.

		<b>L110G</b>
<b>Lift cylinders</b>		2
<b>Cylinder bore</b>	mm (in)	150 (5.9)
<b>Piston rod diameter</b>	mm (in)	80 (3.1)
<b>Stroke</b>	mm (in)	676 (26.6)
<b>Tilt cylinder</b>		1
<b>Cylinder bore</b>	mm (in)	210 (8.3)
<b>Piston rod diameter</b>	mm (in)	110 (4.3)
<b>Stroke</b>	mm (in)	412 (16.2)

		<b>L120G</b>
<b>Lift cylinders</b>		2
<b>Cylinder bore</b>	mm (in)	150 (5.9)
<b>Piston rod diameter</b>	mm (in)	80 (3.1)
<b>Stroke</b>	mm (in)	676 (26.6)
<b>Tilt cylinder</b>		1
<b>Cylinder bore</b>	mm (in)	210 (8.3)
<b>Piston rod diameter</b>	mm (in)	110 (4.3)
<b>Stroke</b>	mm (in)	412 (16.2)





### Hydraulic system

**System supply:** Two load-sensing axial piston pumps with variable displacement. The steering system always has priority.

**Valves:** Double-acting 2-spool valve. The main valve is controlled by a 2-spool pilot valve.

**Lift function:** The valve has three positions; raise, hold and lower position. Inductive/magnetic automatic boom kickout can be switched on and off and is adjustable to any position between maximum reach and full lifting height. Return to dig included.

**Tilt function:** The valve has three functions including rollback, hold and dump. Inductive/magnetic automatic tilt can be adjusted to the desired bucket angle.

**Cylinders:** Double-acting cylinders for all functions

**Filter:** Full flow filtration through 10 micron (absolute) filter cartridge.

		L110G	L120G
Working pressure maximum, pump 1 for working hydraulic system	MPa (bar)	29.0 ± 0.5 (290 ± 5)	29.0 ± 0.5 (290 ± 5)
Flow at engine speed	l (gal)/min MPa (bar)	135 (35.7) 10 (100)	135 (35.7) 10 (100)
Working pressure maximum, pump 2 for steering-, brake-, pilot- and working hydraulic system	MPa (bar)	31.0 ± 0.5 (310 ± 5)	31.0 ± 0.5 (310 ± 5)
Flow at engine speed	l (gal)/min MPa (bar)	135 (35.7) 10 (100)	135 (35.7) 10 (100)
Working pressure maximum, pump 3 for brake- and cooling fan system	MPa (bar)	25.0 ± 0.5 (250 ± 5)	25.0 ± 0.5 (250 ± 5)
Flow at engine speed	l (gal)/min MPa (bar)	33 (8.7) 10 (100)	33 (8.7) 10 (100)
Pilot system, working pressure	MPa (bar)	3.5 (35)	3.5 (35)
Cycle times			
Lift	s	5.4	5.4
Tilt	s	2.1	2.1
Lower, empty	s	2.5	2.5
Total cycle time	s	10.0	10.0

### Steering system

**Steering system:** Load-sensing hydrostatic articulated steering.

**System supply:** The steering system has priority feed from a load-sensing axial piston pump with variable displacement.

**Steering cylinders:** Two double-acting cylinders.

		L110G	L120G
Steering cylinders			
Cylinder bore	mm (in)	80 (3.1)	80 (3.1)
Rod diameter	mm (in)	50 (2.0)	50 (2.0)
Stroke	mm (in)	486 (19.1)	486 (19.1)
Working pressure	MPa (bar)	21 (210)	21 (210)
Maximum flow	l (gal)/min	120 (31.7)	120 (31.7)
Maximum articulation	± °	40	40

### Service

**Service accessibility:** Large, easy-to-open hood covering whole engine department, electrically operated. Fluid filters and component breather air filters promote long service intervals. Possibility to monitor, log and analyze data to facilitate troubleshooting.

		L110G	L120G
Fuel Tank	l (gal)	269 (71.1)	269 (71.1)
Engine coolant	l (gal)	43 (11.4)	43 (11.4)
Hydraulic oil tank	l (gal)	133 (35.1)	133 (35.1)
Transmission oil	l (gal)	38 (10)	38 (10)
Engine oil	l (gal)	22 (5.8)	22 (5.8)
Axle oil front	l (gal)	36 (9.5)	36 (9.5)

# SPECIFICATIONS L110G.

## Tires 23.5 R25 L3

		Standard boom	Long boom
B	mm (in)	6480 (255.1)	7010 (276)
C	mm (in)	3200 (126)	-
D	mm (in)	430 (16.9)	-
F	mm (in)	3380 (133)	-
G	mm (in)	2132 (83.9)	-
J	mm (in)	3710 (146)	4240 (166.9)
K	mm (in)	4030 (158.7)	4550 (179.1)
O	°	55	-
P <sub>max</sub>	°	50	-
R	°	40	41
R <sub>1</sub> *	°	45	-
S	°	66	64
T	mm (in)	80 (3.1)	89 (3.2)
U	mm (in)	480 (18.9)	-
X	mm (in)	2070 (81.5)	-
Y	mm (in)	2670 (105.1)	-
Z	mm (in)	3310 (130.3)	3820 (150.4)
a <sub>2</sub>	mm (in)	5730 (225.6)	-
a <sub>3</sub>	mm (in)	3060 (120.5)	-
a <sub>4</sub>	±°	40	-

\* Carry position SAE

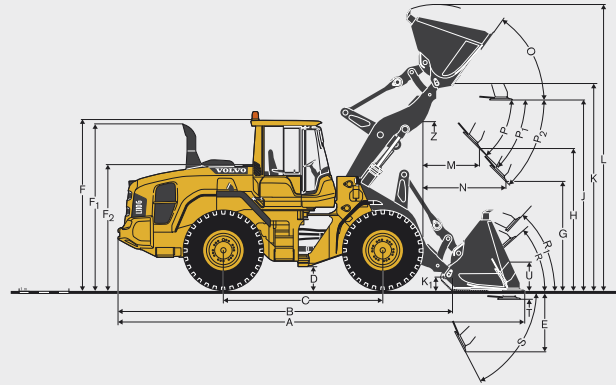

Where applicable, specifications and dimensions are according to ISO 7131, SAE J732, ISO 7546, SAE J742, ISO 14397, SAE J818.

**L110G** Sales code: WLA80832  
 Operating weight  
 (incl. logging weight cwt 140 kg (308 lb):  
 19 840 kg (43,740 lb)  
 Operating load: 5850 kg (12,900 lb)

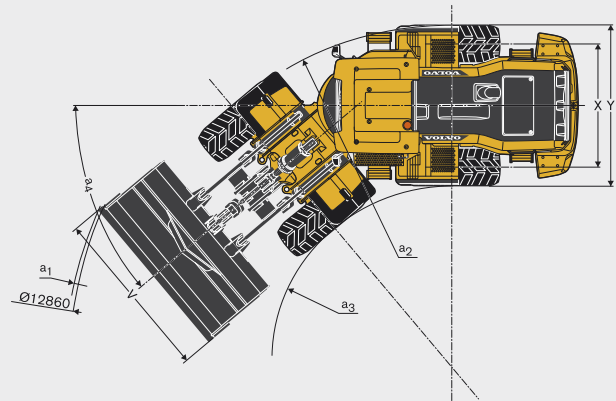





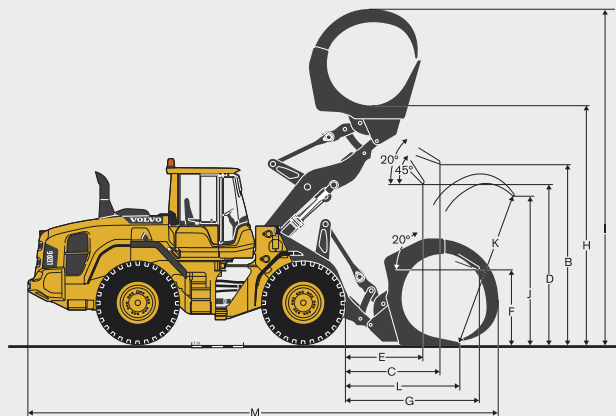



## Tires: 750/65 R25

SAE-Load	kg (lb)	5850 (12,870)
Operating weight without load	kg (lb)	19 840 (43,648)
A	m <sup>2</sup> (yd <sup>2</sup> )	2.4 (2.9)
B	mm (in)	3470 (136.6)
C	mm (in)	1850 (72.8)
D	mm (in)	2850 (112.2)
E	mm (in)	1460 (57.5)
F	mm (in)	1520 (59.8)
G	mm (in)	2720 (107.1)
H	mm (in)	4580 (180.3)
I	mm (in)	6620 (260.6)
J	mm (in)	2790 (109.8)
K	mm (in)	2990 (117.7)
L	mm (in)	2060 (81.1)
M	mm (in)	8770 (345.3)



**L110G**

Tires 23.5R25 XHA2 L3	REHANDLING		GENERAL PURPOSE				ROCK	LIGHT MATERIAL		LONG BOOM	
											
	3.5 (4.6) STE P BOE	3.5 (4.6) STE H BOE	3 (3.9) STE P T	3 (3.9) STE H T	3.4 (4.5) STE P BOE	3.4 (4.5) STE H BOE	2.7 (3.5) SPN P T SEG	5.5 (7.2) LM H	9.5 (12.4) LM H		
Volume, heaped ISO/SAE	m <sup>3</sup> (yd <sup>3</sup> )	3.5 (4.6)	3.5 (4.6)	3 (3.9)	3 (3.9)	3.4 (4.5)	3.4 (4.5)	2.7 (3.5)	5.5 (7.2)	9.5 (12.4)	-
Volume at 110% fill factor	m <sup>3</sup> (yd <sup>3</sup> )	3.9 (5.1)	3.9 (5.1)	3.3 (4.3)	3.3 (4.3)	3.7 (4.8)	3.7 (4.8)	3 (3.9)	6.1 (8)	10.5 (13.7)	-
Static tipping load, straight	kg (lb)	13 340 (29,348)	12 670 (27,874)	13 670 (30,074)	12 990 (28,578)	13 230 (29,106)	12 570 (27,654)	13 670 (30,074)	11 870 (26,114)	11 960 (26,312)	-2680 (-5,896)
at 35° turn	kg (lb)	11 850 (26,070)	11 230 (24,706)	12 170 (26,774)	11 540 (25,388)	11 750 (25,850)	11 140 (24,508)	12 130 (26,686)	10 450 (22,990)	10 510 (23,122)	-2450 (-5,390)
at full turn	kg (lb)	11 420 (25,124)	10 810 (23,782)	11 730 (25,806)	11 110 (24,442)	11 320 (24,904)	10 710 (23,562)	11 680 (25,696)	10 040 (22,088)	10 090 (22,198)	-2380 (-5,236)
Breakout force	kN (lbf)	1621 (36,442)	1498 (33,676)	1748 (39,297)	1604 (36,059)	1577 (35,452)	1459 (32,800)	1431 (32,170)	1153 (25,920)	1006 (22,616)	3 (675)
A	mm (in)	7970 (313.8)	8080 (318.1)	8090 (318.5)	8200 (322.8)	8010 (315.4)	8120 (319.7)	8310 (327.2)	8520 (335.4)	8810 (346.9)	610 (24)
E	mm (in)	1220 (48)	1320 (52)	1340 (52.8)	1440 (56.7)	1260 (49.6)	1360 (53.5)	1510 (59.4)	1710 (67.3)	1970 (77.6)	-
H	mm (in)	2820 (111)	2750 (108.3)	2740 (107.9)	2670 (105.1)	2790 (109.8)	2720 (107.1)	2610 (102.8)	2410 (94.9)	2200 (86.6)	520 (20.5)
L	mm (in)	5440 (214.2)	5510 (216.9)	5550 (218.5)	5610 (220.9)	5620 (221.3)	5670 (223.1)	5550 (218.5)	5830 (229.5)	6000 (236.2)	510 (20.1)
M	mm (in)	1170 (46.1)	1250 (49.2)	1280 (50.4)	1370 (53.9)	1200 (47.2)	1280 (50.4)	1400 (55.1)	1520 (59.8)	1730 (68.1)	-40 (-1.6)
N	mm (in)	1710 (67.3)	1750 (68.9)	1790 (70.5)	1820 (71.7)	1730 (68.1)	1770 (69.7)	1810 (71.3)	1790 (70.5)	1800 (70.9)	430 (16.9)
V	mm (in)	3000 (118.1)	3000 (118.1)	2880 (113.4)	2880 (113.4)	2880 (113.4)	2880 (113.4)	2880 (113.4)	3000 (118.1)	3400 (133.9)	-
a1 clearance circle	mm (in)	12 750 (502.9)	12 800 (503.9)	12 710 (500.4)	12 770 (502.8)	12 660 (498.4)	12 710 (500.4)	12 830 (505.1)	13 060 (514.2)	13 610 (535.8)	-
Operating weight	kg (lb)	18 420 (40,524)	18 650 (41,030)	18 280 (40,216)	18 490 (40,678)	18 480 (40,656)	18 690 (41,118)	19 490 (42,878)	19 030 (41,866)	19 250 (42,350)	300 (660)

**Bucket Selection Chart**

The chosen bucket is determined by the density of the material and the expected bucket fill factor. The actual bucket volume is often larger than the rated capacity, due to the features of the TP linkage, including an open bucket design, good rollback angles in all positions and good bucket filling performance. The example represents a standard boom configuration. Example: Sand and gravel. Fill factor ~ 105%. Density 1.6 t/m<sup>3</sup> (2,700 lb/yd<sup>3</sup>). Result: The 3.4 m<sup>3</sup> (4.5 yd<sup>3</sup>) bucket carries 3.6 m<sup>3</sup> (4.7 yd<sup>3</sup>). For optimum stability always consult the bucket selection chart.

Material	Bucket fill, %	Material density, t/m <sup>3</sup> (lb/yd <sup>3</sup> )	ISO/SAE bucket volume, m <sup>3</sup> (yd <sup>3</sup> )	Actual volume, m <sup>3</sup> (yd <sup>3</sup> )
Earth/Clay	~ 110	1.8 (3,030)	3.0 (3.9)	3.3 (4.3)
		1.6 (2,700)	3.4 (4.5)	3.7 (4.8)
Sand/Gravel	~ 105	1.8 (3,030)	3.0 (3.9)	3.2 (4.2)
		1.6 (2,700)	3.4 (4.5)	3.6 (4.7)
Aggregate	~ 100	1.8 (3,030)	3.5 (4.6)	3.5 (4.6)
Rock	≤100	1.7 (2,866)	2.7 (3.5)	2.7 (3.5)

The size of rock buckets is optimized for optimal penetration and filling capability rather than the density of the material.

**Supplemental Operating Data**

		Standard boom	Long boom
Tires 23.5 R25 L3		23.5 R25 L3	23.5 R25 L3
Width over tires	mm (in)	2670 (105.1)	2670 (105.1)
Ground clearance	mm (in)	430 (16.9)	430 (16.9)
Tipping load, full turn	kg (lb)	11 710 (25,762)	9330 (20,526)
Operating weight	kg (lb)	18 330 (40,326)	18 330 (40,326)

Type of boom	Type of bucket	ISO/SAE Bucket volume	L110G Material density: t/m <sup>3</sup> (lb/yd <sup>3</sup> )								
			0.8 (1,349)	1.0 (1,686)	1.2 (2,024)	1.4 (2,361)	1.6 (2,698)	1.8 (3,035)	2.0 (3,373)		
Standard boom	Rehanding	P 3.5 m <sup>3</sup> (4.6 yd <sup>3</sup> )					3.7 (4.8)	3.5 (4.6)			
		H 3.5 m <sup>3</sup> (4.6 yd <sup>3</sup> )					3.7 (4.8)	3.5 (4.6)			
	General purpose	P 3.0 m <sup>3</sup> (3.9 yd <sup>3</sup> )						3.3 (4.3)	3.0 (3.9)		
		H 3.0 m <sup>3</sup> (3.9 yd <sup>3</sup> )						3.3 (4.3)	3.0 (3.9)		
	Rock	P 2.7 m <sup>3</sup> (3.5 yd <sup>3</sup> )								2.7 (3.5)	2.6 (3.3)
		H 2.7 m <sup>3</sup> (3.5 yd <sup>3</sup> )								2.7 (3.5)	2.6 (3.3)
Long boom	Light material	H 5.5 m <sup>3</sup> (7.2 yd <sup>3</sup> )	10.0 (13.0)				5.8 (7.6)	5.5 (7.2)			
		H 9.5 m <sup>3</sup> (12.4 yd <sup>3</sup> )		9.5 (12.4)							
	Rehanding	P 3.5 m <sup>3</sup> (4.6 yd <sup>3</sup> )						3.7 (4.8)	3.5 (4.6)		
		H 3.5 m <sup>3</sup> (4.6 yd <sup>3</sup> )						3.7 (4.8)	3.5 (4.6)		
	General purpose	P 3.0 m <sup>3</sup> (3.9 yd <sup>3</sup> )							3.3 (4.3)	3.0 (3.9)	
		H 3.0 m <sup>3</sup> (3.9 yd <sup>3</sup> )							3.3 (4.3)	3.0 (3.9)	
Rock	P 2.7 m <sup>3</sup> (3.5 yd <sup>3</sup> )								2.7 (3.5)	2.6 (3.3)	
	H 2.7 m <sup>3</sup> (3.5 yd <sup>3</sup> )								2.7 (3.5)	2.6 (3.3)	
Light material	H 5.5 m <sup>3</sup> (7.2 yd <sup>3</sup> )		5.8 (7.6)					5.5 (7.2)			
	H 9.5 m <sup>3</sup> (12.4 yd <sup>3</sup> )			9.5 (12.4)							

How to read bucket fill factor

# SPECIFICATIONS L120G.

## Tires 23.5 R25 L3

		Standard boom	Long boom
B	mm (in)	6580 (259)	7067 (278)
C	mm (in)	3200 (126)	-
D	mm (in)	440 (17.3)	-
F	mm (in)	3380 (133)	-
G	mm (in)	2132 (83.9)	-
J	mm (in)	3770 (149.2)	4306 (169.5)
K	mm (in)	4100 (161.4)	4618 (181.8)
O	°	54	-
P <sub>max</sub>	°	51	-
R	°	42	42.5
R <sub>1</sub> *	°	47	-
S	°	67	63.9
T	mm (in)	104 (40.1)	134 (5.3)
U	mm (in)	510 (20.1)	-
X	mm (in)	2070 (81.5)	-
Y	mm (in)	2670 (105.1)	-
Z	mm (in)	3340 (131.5)	3715 (146.2)
a <sub>2</sub>	mm (in)	5730 (225.6)	-
a <sub>3</sub>	mm (in)	3060 (120.5)	-
a <sub>4</sub>	±°	40	-

\* Carry position SAE

**L120G** Sales code: WLA80832  
 Operating weight  
 (incl. logging weight cwt 680 kg (1,500 lb):  
 20 600 kg (45,415 lb)  
 Operating load: 6400 kg (14,110 lb)

## Tires L120G: Standard

Attachment 80832 Sorting Grapple



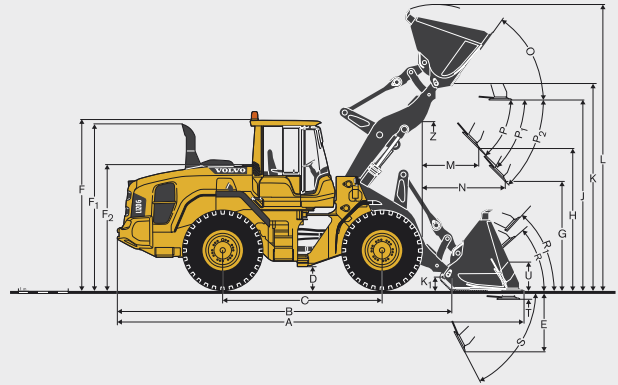



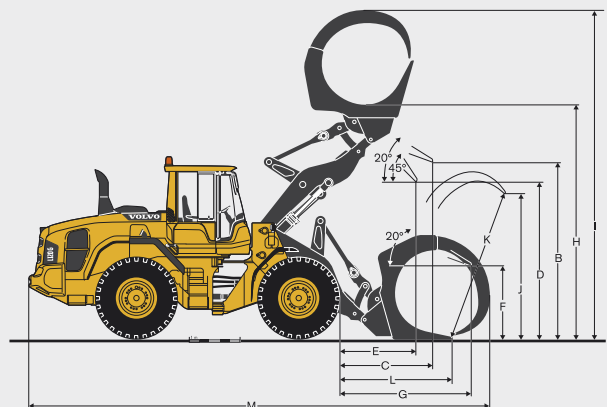
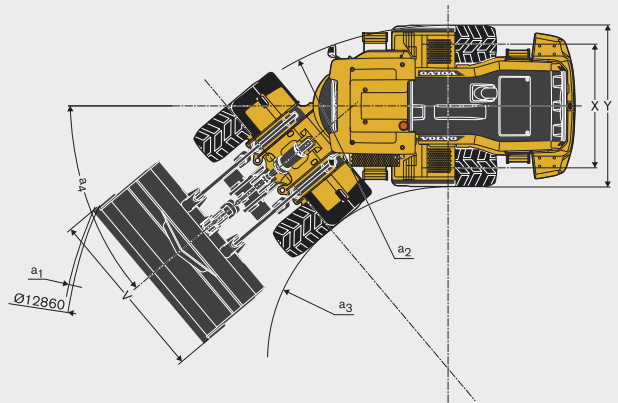

SAE-Load	kg (lb)	6400 (14,080)
Operating weight without load	kg (lb)	20 630 (45,386)
A	m <sup>2</sup> (yd <sup>2</sup> )	2,4 (2.9)
B	mm (in)	3550 (139.8)
C	mm (in)	1890 (74.4)
D	mm (in)	2920 (115)
E	mm (in)	1500 (59.1)
F	mm (in)	1530 (60.2)
G	mm (in)	2790 (109.8)
H	mm (in)	4660 (183.5)
I	mm (in)	6690 (263.4)
J	mm (in)	2790 (109.8)
K	mm (in)	2990 (117.7)
L	mm (in)	2150 (84.6)
M	mm (in)	8860 (348.8)



Where applicable, specifications and dimensions are according to ISO 7131, SAE J732, ISO 7546, SAE J742, ISO 14397, SAE J818.







**L120G**

Tires 23.5R25 XHA2 L3	REHANDLING		GENERAL PURPOSE				ROCK	LIGHT MATERIAL		LONG BOOM	
											
	3.5 (4.6) STE P BOE	3.5 (4.6) STE H BOE	3 (3.9) STE P T	3 (3.9) STE H T	3.4 (4.5) STE P BOE	3.4 (4.5) STE H BOE	2.7 (3.5) SPN P T SEG	5.5 (7.2) LM H	9.5 (12.4) LM H		
Volume, heaped ISO/SAE	m <sup>3</sup> (yd <sup>3</sup> )	3.8 (5)	3.8 (5)	3.3 (4.3)	3.3 (4.3)	3.6 (4.7)	3.6 (4.7)	3 (3.9)	5.5 (7.2)	9.5 (12.4)	-
Volume at 110% fill factor	m <sup>3</sup> (yd <sup>3</sup> )	4.2 (5.5)	4.2 (5.5)	3.6 (4.7)	3.6 (4.7)	4 (5.2)	4 (5.2)	3.3 (4.3)	6.1 (8)	10.5 (13.7)	-
Static tipping load, straight	kg (lb)	14 250 (31,350)	13 570 (29,854)	14 730 (32,406)	14 390 (31,658)	14 700 (32,340)	13 970 (30,734)	14 750 (32,450)	12 910 (28,402)	13 010 (28,622)	-2750 (-6,040)
at 35° turn	kg (lb)	12 610 (27,742)	11 980 (26,356)	13 070 (28,754)	12 740 (28,028)	13 010 (28,622)	12 330 (27,126)	13 060 (28,732)	11 350 (24,970)	11 420 (25,124)	-2500 (5,515)
at full turn	kg (lb)	12 130 (26,686)	11 510 (25,322)	12 580 (27,676)	12 250 (26,950)	12 510 (27,522)	11 850 (26,070)	12 570 (27,654)	10 880 (23,936)	10 950 (24,090)	-2440 (5,360)
Breakout force	kN (lbf)	163.7 (36,801)	151.8 (34,126)	188 (42,264)	172.4 (38,757)	172.9 (38,869)	159.6 (35,880)	150.6 (33,856)	121.6 (27,337)	106.1 (23,852)	6 (1,350)
A	mm (in)	8140 (320.5)	8240 (324.4)	8170 (321.7)	8270 (325.6)	8050 (316.9)	8160 (321.3)	8390 (330.3)	8610 (339)	8910 (350.8)	506 (20)
E	mm (in)	1300 (51.2)	1400 (55.1)	1330 (52.4)	1430 (56.3)	1230 (48.4)	1330 (52.4)	1520 (59.8)	1730 (68.1)	2000 (78.7)	29 (1.1)
H	mm (in)	2840 (111.8)	2770 (109.1)	2830 (111.4)	2760 (108.7)	2900 (114.2)	2830 (111.4)	2690 (105.9)	2470 (97.2)	2270 (89.4)	519 (20.4)
L	mm (in)	5580 (219.7)	5640 (222)	5700 (224.4)	5760 (226.8)	5750 (226.4)	5820 (229.1)	5690 (224)	5900 (232.3)	6070 (239)	516 (20.3)
M	mm (in)	1250 (49.2)	1330 (52.4)	1300 (51.2)	1390 (54.7)	1190 (46.9)	1280 (50.4)	1440 (56.7)	1560 (61.4)	1760 (69.3)	-25 (-1)
N	mm (in)	1820 (71.7)	1860 (73.2)	1870 (73.6)	1910 (75.2)	1800 (70.9)	1840 (72.4)	1920 (75.6)	1890 (74.4)	1910 (75.2)	428 (16.9)
V	mm (in)	3000 (118.1)	3000 (118.1)	3000 (118.1)	3000 (118.1)	3000 (118.1)	3000 (118.1)	2880 (113.4)	3000 (118.1)	3400 (133.9)	-
a1 clearance circle	mm (in)	12 840 (505.5)	12 900 (507.9)	12 870 (506.7)	12 930 (509.1)	12 800 (503.9)	12 850 (505.9)	12 890 (507.5)	13 130 (516.9)	13 660 (537.8)	-
Operating weight	kg (lb)	19 300 (42,460)	19 520 (42,944)	19 170 (42,174)	19 350 (42,570)	19 350 (42,570)	19 570 (43,054)	20 190 (44,418)	19 830 (43,626)	20 050 (44,110)	275 (605)

**Bucket Selection Chart**

The chosen bucket is determined by the density of the material and the expected bucket fill factor. The actual bucket volume is often larger than the rated capacity, due to the features of the TP linkage, including an open bucket design, good rollback angles in all positions and good bucket filling performance. The example represents a standard boom configuration. Example: Sand and gravel. Fill factor ~ 105%. Density 1.6 t/m<sup>3</sup> (2,700 yd<sup>3</sup>). Result: The 3.6 m<sup>3</sup> (4.7 yd<sup>3</sup>) bucket carries 3.8 m<sup>3</sup> (5 yd<sup>3</sup>). For optimum stability always consult the bucket selection chart.

Material	Bucket fill, %		Material density, t/m <sup>3</sup> (lb/yd <sup>3</sup> )	ISO/SAE bucket volume, m <sup>3</sup> (yd <sup>3</sup> )	Actual volume, m <sup>3</sup> (yd <sup>3</sup> )
Earth/Clay	~ 110		1.8 (3,030)	3.3 (4.3)	3.6 (4.7)
			1.6 (2,700)	3.6 (4.7)	3.9 (5.1)
Sand/Gravel	~ 105		1.8 (3,030)	3.3 (4.3)	3.5 (4.6)
			1.6 (2,700)	3.6 (4.7)	3.8 (5.0)
Aggregate	~ 100		1.8 (3,030)	3.8 (5.0)	3.8 (5.0)
Rock	≤100		1.7 (2,866)	3.0 (3.9)	3.0 (3.9)

The size of rock buckets is optimized for optimal penetration and filling capability rather than the density of the material.

**Supplemental Operating Data**

Tires 23.5 R25 L3	Standard boom		Long boom	
	23.5 R25 L3		23.5 R25 L3	
Width over tires	mm (in)	2670 (105.1)	2670 (105.1)	
Ground clearance	mm (in)	440 (17.3)	440 (17.3)	
Tipping load, full turn	kg (lb)	12 570 (27,654)	10 133 (22,293)	
Operating weight	kg (lb)	19 127 (42,079)	19 402 (42,684)	

Type of boom	Type of bucket	ISO/SAE Bucket volume	Material density: t/m <sup>3</sup> (lb/yd <sup>3</sup> )									
			0.8 (1,349)	1.0 (1,686)	1.2 (2,024)	1.4 (2,361)	1.6 (2,698)	1.8 (3,035)	2.0 (3,373)			
Standard boom	Rehanding	P 3.8 m <sup>3</sup> (5.0 yd <sup>3</sup> )							4.0 (5.2)	3.8 (5.0)		
		H 3.8 m <sup>3</sup> (5.0 yd <sup>3</sup> )							4.0 (5.2)	3.8 (5.0)		
	General purpose	P 3.3 m <sup>3</sup> (4.3 yd <sup>3</sup> )								3.6 (4.7)	3.3 (4.3)	
		H 3.3 m <sup>3</sup> (4.3 yd <sup>3</sup> )								3.6 (4.7)	3.3 (4.3)	
	Rock	P 3.0 m <sup>3</sup> (3.9 yd <sup>3</sup> )									3.0 (3.9)	2.8 (3.7)
		H 3.0 m <sup>3</sup> (3.9 yd <sup>3</sup> )									3.0 (3.9)	2.8 (3.7)
Long boom	Light material	H 5.5 m <sup>3</sup> (7.2 yd <sup>3</sup> )	10.0 (13.0)	5.8 (7.6)	3.5 (7.2)							
		H 9.5 m <sup>3</sup> (12.4 yd <sup>3</sup> )		9.5 (12.4)								
	Rehanding	P 3.8 m <sup>3</sup> (5.0 yd <sup>3</sup> )							4.0 (5.2)	3.8 (5.0)		
		P 3.3 m <sup>3</sup> (4.3 yd <sup>3</sup> )							3.6 (4.7)	3.3 (4.3)		
General purpose	P 3.6 m <sup>3</sup> (4.7 yd <sup>3</sup> )							4.0 (5.2)	3.6 (4.7)			
	P 3.0 m <sup>3</sup> (3.9 yd <sup>3</sup> )								3.1 (4.1)	3.0 (3.9)		
Rock	P 3.0 m <sup>3</sup> (3.9 yd <sup>3</sup> )								3.1 (4.1)	3.0 (3.9)		
	H 5.5 m <sup>3</sup> (7.2 yd <sup>3</sup> )	5.8 (7.6)	5.5 (7.2)									
Bucket fill												
			P=Pin-on H=Hook-on									

How to read bucket fill factor

# EQUIPMENT.

## STANDARD EQUIPMENT

	L110G	L120G
<b>Service and maintenance</b>		
Engine oil remote drain and fill	•	•
Transmission oil remote drain and fill	•	•
Lubrication manifolds, ground accessible	•	•
Pressure check connections: transmission and hydraulic, quick-connects	•	•
Tool box, lockable	•	•
CareTrack	•	•
Telematics, 3-Year Subscription	•	•
<b>Engine</b>		
Exhaust after-treatment system	•	•
Two air cleaners, pre-cleaner, primary and secondary filter	•	•
Indicator glass for coolant level	•	•
Preheating of induction air	•	•
Fuel pre-filter with water trap	•	•
Fuel filter	•	•
Crankcase breather oil trap	•	•
Exhaust heat insulation	•	•
Exterior radiator air intake protection	•	•
Reversible cooling fan	•	•
<b>Electrical system</b>		
24 V, pre-wired for optional accessories	•	•
Alternator 24V/110A	•	•
Battery disconnect switch with removable key	•	•
Fuel gauge	•	•
Hour meter	•	•
Electric horn	•	•
Instrument cluster:		
Fuel level		
Transmission temperature	•	•
Coolant temperature		
Instrument lighting		
Lighting:		
Twin halogen front headlights with high and low beams		
Parking lights	•	•
Double brake and tail lights		
Turn signals with flashing hazard light function		
Halogen work lights (2 front and 2 rear)		
Rear view camera including monitor, color	•	•
<b>Contronic monitoring system</b>		
Monitoring and logging of machine data	•	•
Contronic display	•	•
Fuel consumption	•	•
Ambient temperature	•	•
Clock	•	•
Test function for warning and indicator lights	•	•
Brake test	•	•
Test function, sound level at max fan speed	•	•
Warning and indicator lights:		
Battery charging	•	•
Parking brake		
Warning and display message:		
Regeneration		
Engine coolant temperature		
Charge-air temperature		
Engine oil temperature		
Engine oil pressure		
Transmission oil temperature		
Transmission oil pressure		
Hydraulic oil temperature	•	•
Brake pressure		
Parking brake applied		
Brake charging		
Over-speed at direction change		
Axle oil temperature		
Steering pressure		
Crankcase pressure		
Attachment lock open		
Level warnings:		
Fuel level		
Engine oil level		
Engine coolant level	•	•
Transmission oil level		
Hydraulic oil level		
Washer fluid level		
Engine torque reduction in case of malfunction indication:		
High engine coolant temperature		
High engine oil temperature	•	•
Low engine oil pressure		
High crankcase pressure		
High charge-air temperature		

Engine shutdown to idle in case of malfunction indication:		
High transmission oil temperature	•	•
Slip in transmission clutches		
Keypad, background lit	•	•
Start interlock when gear is engaged	•	•
<b>Drivetrain</b>		
Automatic Power Shift	•	•
Fully automatic gearshifting, 1-4	•	•
PWM-controlled gearshifting	•	•
Forward and reverse switch by hydraulic lever console	•	•
Indicator glass for transmission oil level	•	•
Differentials:		
Front, 100% hydraulic differential lock. Rear, conventional.	•	•
<b>Brake system</b>		
Dual brake circuits	•	•
Dual brake pedals	•	•
Secondary brake system	•	•
Parking brake, electrical-hydraulic	•	•
Brake wear indicators, self adjusting brakes	•	•
<b>Cab</b>		
ROPS (ISO 3471), FOPS (ISO 3449)	•	•
Single key kit door/start	•	•
Acoustic inner lining	•	•
Ashtray	•	•
24 V power outlet	•	•
Lockable door	•	•
Cab heating with fresh air inlet and defroster	•	•
Fresh air inlet with two filters	•	•
Automatic heat control	•	•
Floor mat	•	•
Dual interior lights	•	•
Dual interior rear-view mirrors	•	•
Dual exterior rear-view mirrors	•	•
Sliding window, right side	•	•
Tinted safety glass	•	•
Retractable seat belt (SAE J386)	•	•
Adjustable steering wheel	•	•
Storage compartment	•	•
Document pocket	•	•
Sun visor	•	•
Beverage holder	•	•
Windshield washer front and rear	•	•
Windshield wipers front and rear	•	•
Interval function for front and rear wipers	•	•
<b>Hydraulic system</b>		
Main valve, double acting 2-spool with el-hydraulic pilots	•	•
Variable displacement axial piston pumps (3) for:		
1 Working hydraulic system		
2 Working hydraulic system,	•	•
Steering- and Brake system		
3 Cooling fan and Brake system		
Electro-hydraulic servo controls	•	•
Electric level lock	•	•
Boom kick-out, automatic	•	•
Bucket positioner, automatic, RTD, automatic	•	•
Double-acting hydraulic cylinders	•	•
Indicator glass for hydraulic oil level	•	•
Hydraulic oil cooler	•	•
<b>External equipment</b>		
Fenders, front and rear	•	•
Viscous cab mounts	•	•
Rubber engine and transmission mounts	•	•
Easy-to-open side panels	•	•
Frame, joint lock	•	•
Vandalism lock prepared for		
Batteries	•	•
Engine compartment		
Radiator grille		
Lifting eyes	•	•
Tie-down eyes	•	•
Tow hitch	•	•
CareTrack, GSM	•	•
CareTrack, GSM/Satellite	•	•
Counterweight, pre-drilled for optional guards	•	•

## OPTIONAL EQUIPMENT

	L110G	L120G
<b>Service and maintenance</b>		
Automatic lubrication system	•	•
Automatic lubrication system for long boom	•	•
Grease nipple guards	•	•
Oil sampling valve	•	•
Refill pump for grease to lube system	•	•
Tool kit	•	•
Wheel nut wrench kit	•	•
<b>Engine</b>		
Air pre-cleaner, cyclone type	•	•
Air pre-cleaner, cyclone type, two-stage	•	•
Air pre-cleaner, oil-bath type	•	•
Air pre-cleaner, turbo type	•	•
Radiator corrosion protection	•	•
Engine auto shutdown	•	•
Engine block heater 230V/110V	•	•
ESW, Disabled engine protection	•	•
Air intake protection (for grill in waste)	•	•
Fuel fill strainer	•	•
Fuel heater	•	•
Hand throttle control	•	•
Max. fan speed, hot climate	•	•
Radiator, corrosion-protected	•	•
Reversible cooling fan and axle oil cooler	•	•
Fuel filter, extra	•	•
<b>Electrical system</b>		
Alternator, 80 A with air filter	•	•
Anti-theft device	•	•
Headlights, assembly left	•	•
License plate holder, lighting	•	•
Rear-view mirrors, adjustable, el. heated	•	•
Rear view mirrors, Long arm	•	•
Rear view mirrors, adjustable, el. heated, Long arm	•	•
Reduced function working lights, reverse gear activated	•	•
Reverse alarm	•	•
Reverse warning light, strobe lighting	•	•
Shortened headlight support brackets	•	•
Side marker lamps	•	•
Rotating beacon	•	•
Working lights, attachments	•	•
Working lights front, high intensity discharge (HID)	•	•
Working lights front, on cab, dual	•	•
Working lights front, extra	•	•
Working lights rear, on cab	•	•
Working lights rear, on cab, dual	•	•
<b>Cab</b>		
Anchorage for Operator's manual	•	•
Automatic Climate Control, ACC	•	•
ACC control panel, with Fahrenheit scale	•	•
Asbestos dust protection filter	•	•
Cab air pre-cleaner, cyclone type	•	•
Carbon filter	•	•
Cab roof, heavy-duty	•	•
Cover plate, under cab	•	•
Lunch box holder	•	•
Armrest, operator's seat, ISRI, left only	•	•
Operator's seat, KAB, air suspension, heavy-duty, for CDC and/or elsevo	•	•
Radio installation kit including 11 amp 12 volt outlet, left side	•	•
Radio installation kit including 11 amp 12 volt outlet, right side	•	•
Radio installation kit including 20 amp 12 volt outlet	•	•
Radio with CD-player	•	•
Seat belt, 3", (width 75 mm)	•	•
Steering wheel knob	•	•
Sun blinds, rear windows	•	•
Sun blinds, side windows	•	•
Timer cab heating	•	•
Window, sliding, door	•	•
Universal door/ignition key	•	•

Front view mirror	•	•
<b>Drivetrain</b>		
Differential lock front 100%, Limited Slip rear	•	•
Speed limiter, 20 km/h (12 mph)	•	•
Speed limiter, 30 km/h (18 mph)	•	•
Speed limiter, 40 km/h (25 mph)	•	•
Wheel/axle seal guards	•	•
<b>Brake system</b>		
Oil cooler and filter front & rear axle	•	•
Stainless steel, brake lines	•	•
<b>Hydraulic system</b>		
Attachment bracket, welded	•	•
Boom suspension system	•	•
Separate attachment locking, standard boom	•	•
Separate attachment locking, long boom	•	•
Arctic kit, attachment locking hoses and 3rd hydraulic function	•	•
Arctic kit, pilot hoses and brake accum. including hydraulic oil	•	•
Boom cylinder hose and tube guards	•	•
Boom cylinder hose and tube guards for long boom	•	•
Hydraulic fluid, biodegradable, Volvo	•	•
Hydraulic fluid, fire-resistant	•	•
Hydraulic fluid, for hot climate	•	•
Electro-hydraulic function, 3rd	•	•
Electro-hydraulic function, 3rd for long boom	•	•
Electro-hydraulic function, 3rd-4th	•	•
Electro-hydraulic function, 3rd-4th for long boom	•	•
Electro-hydraulic servo controls for long boom	•	•
<b>External equipment</b>		
Cab ladder, rubber-suspended	•	•
Deleted front mudguards & wideners rear	•	•
Mudguard widener, front/rear for 80-series tires	•	•
Mudguard widener, front/rear for 65-series tires	•	•
Fire suppression system	•	•
Mudguards, full cover, rear for 80-series tires	•	•
Mudguards, full cover, rear for 65-series tires	•	•
Long boom	•	•
Long boom for electro-hydraulic	•	•
<b>Protective equipment</b>		
Belly guard front	•	•
Belly guard rear	•	•
Belly guard rear, oil pan	•	•
Cover plate, heavy-duty, front frame	•	•
Cab roof heavy duty	•	•
Guards for front headlights	•	•
Guards for radiator grill	•	•
Guards for tail lights	•	•
Windows, side and rear guards	•	•
Windshield guard	•	•
Corrosion protection, painting of machine	•	•
Corrosion protection, painting of attachment bracket	•	•
Bucket Teeth protection	•	•
<b>Other equipment</b>		
Comfort Drive Control (CDC)	•	•
Counterweight, logging	•	•
Counter weight, block handling	•	•
Counterweight, re-handling	•	•
Counterweight, signal painted, chevrons	•	•
Log pusher	•	•
Secondary steering with automatic test function	•	•
Noise reduction kit, exterior	•	•
Sign, slow moving vehicle	•	•
<b>Tires</b>		
26.5 R25	•	•
775/65 R29	•	•

# VOLVO CONSTRUCTION EQUIPMENT

Volvo Construction Equipment is different. Our machines are designed, built and supported in a different way. That difference comes from an engineering heritage of over 175 years. A heritage of thinking first about the people who actually use the machines. About how to help them be safer, more comfortable, more productive. About the environment we all share. The result of that thinking is a growing range of machines and a global support network dedicated to helping you do more. People around the world are proud to use Volvo.

Not all products are available in all markets. Under our policy of continuous improvement, we reserve the right to change specifications and design without prior notice. The illustrations do not necessarily show the standard version of the machine.

# **VOLVO**

**Volvo Construction Equipment**  
[www.volvoce.com/na](http://www.volvoce.com/na)

Ref. No. VOE2210009239  
Printed in USA 12/11 - 0.8  
Volvo, Asheville  
Copyright © 2011 Volvo

English  
USA